

2N3906 TRANSISTOR (PNP)

FEATURE

- PNP silicon epitaxial planar transistor for switching and Amplifier applications
- As complementary type, the NPN transistor 2N3904 is Recommended
- This transistor is also available in the SOT-23 case with the type designation MMBT3906

MAXIMUM RATINGS ($T_a=25^{\circ}\text{C}$ unless otherwise noted)

Symbol	Parameter	Value	Unit
V_{CBO}	Collector-Base Voltage	-40	V
V_{CEO}	Collector-Emitter Voltage	-40	V
V_{EBO}	Emitter-Base Voltage	-5	V
I_C	Collector Current -Continuous	-0.2	A
P_C	Collector Power Dissipation	0.625	W
T_J	Junction Temperature	150	$^{\circ}\text{C}$
T_{stg}	Storage Temperature	-55~150	$^{\circ}\text{C}$

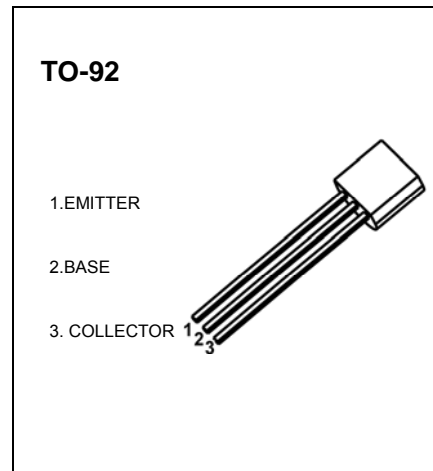

ELECTRICAL CHARACTERISTICS ($T_a=25^{\circ}\text{C}$ unless otherwise specified)

Parameter	Symbol	Test conditions	Min	Typ	Max	Unit
Collector-base breakdown voltage	$V_{(BR)CBO}$	$I_C = -10\mu\text{A}, I_E=0$	-40			V
Collector-emitter breakdown voltage	$V_{(BR)CEO}$	$I_C = -1\text{mA}, I_B=0$	-40			V
Emitter-base breakdown voltage	$V_{(BR)EBO}$	$I_E = -10\mu\text{A}, I_C=0$	-5			V
Collector cut-off current	I_{CBO}	$V_{CB} = -40\text{V}, I_E=0$			-0.1	μA
Collector cut-off current	I_{CEX}	$V_{CE} = -30\text{V}, V_{BE(off)} = -3\text{V}$			-50	nA
Emitter cut-off current	I_{EBO}	$V_{EB} = -5\text{V}, I_C=0$			-0.1	μA
DC current gain	h_{FE1}	$V_{CE} = -1\text{V}, I_C = -10\text{mA}$	100		400	
	h_{FE2}	$V_{CE} = -1\text{V}, I_C = -50\text{mA}$	60			
	h_{FE3}	$V_{CE} = -1\text{V}, I_C = -100\text{mA}$	30			
Collector-emitter saturation voltage	$V_{CE(sat)}$	$I_C = -50\text{mA}, I_B = -5\text{mA}$			-0.4	V
Base-emitter saturation voltage	$V_{BE(sat)}$	$I_C = -50\text{mA}, I_B = -5\text{mA}$			-0.95	V
Transition frequency	f_T	$V_{CE} = -20\text{V}, I_C = -10\text{mA}$ $f = 100\text{MHz}$	250			MHz
Delay Time	t_d	$V_{CC} = -3\text{V}, V_{BE} = -0.5\text{V}$			35	ns
Rise Time	t_r	$I_C = -10\text{mA}, I_{B1} = -1\text{mA}$			35	ns
Storage Time	t_s	$V_{CC} = -3\text{V}, I_C = -10\text{mA}$			225	ns
Fall Time	t_f	$I_{B1} = I_{B2} = -1\text{mA}$			75	ns

CLASSIFICATION OF h_{FE1}

Rank	O		
Range	150-400		